

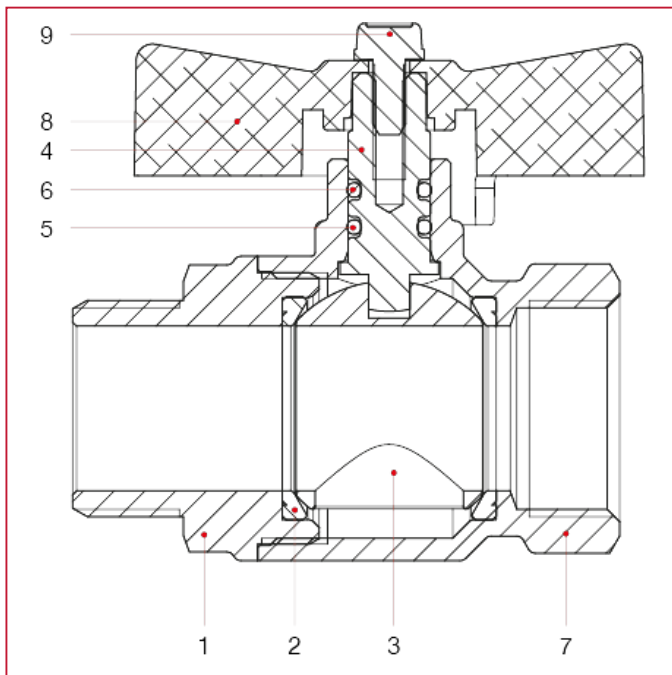

TRINKWASSER KUGELHÄHNE: IDEAL DVGW

293P Kugelhahn Ideal DVGW, voller Durchgang

WERKSTOFFE



POS.	BESCHREIBUNG	N.	MATERIAL
1	Muffe mit Außengewinde	1	Vernickeltes Messing CW617N
2	Sitz	2	P.T.F.E.
3	Kugel	1	Verchromtes Messing CW617N
4	Spindel	1	Messing CW614N
5	O-Ring	1	NBR
6	O-Ring	1	Viton®
7	Gehäuse	1	Vernickeltes Messing CW617N
8	T-Griff	1	Lackiertes Aluminium
9	Schraube	1	Verzinkter Stahl C4C