

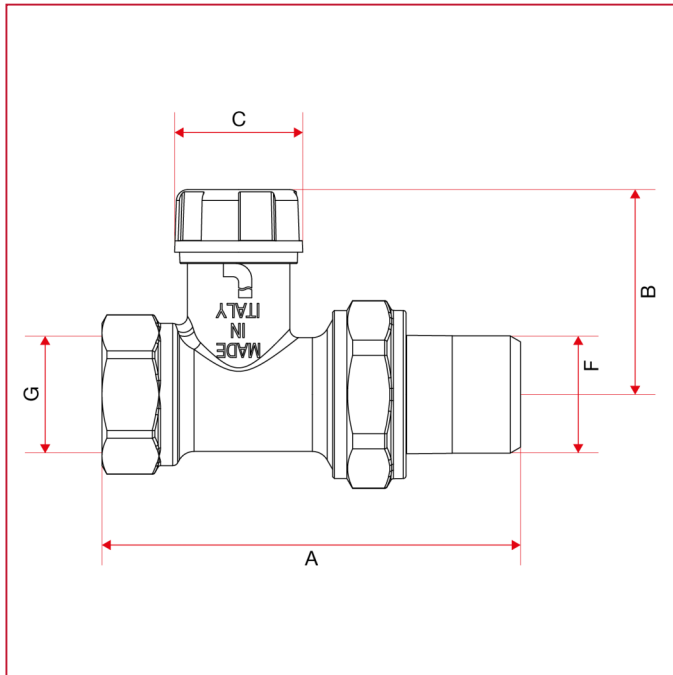

HANDVENTIL UND RÜCKLAUFVERSCHRAUBUNG

296 Gerade Rücklaufverschraubung

GESAMTABMESSUNGEN



	1/2"	3/4"
DN	15	20
A	73,5	77,5
B	36	39
C	22,5	22,5
F	1/2"	3/4"
G	1/2"	3/4"
Kg/cm ² bar	10	10
LBS - psi	145	145