



ELECTRIC ACTUATORS AND ZONE BALL VALVES

980 2-way zone ball valve

INSTRUCTIONS

ACTUATOR INSTALLATION:

- 1) Line up the manoeuvre stem in the position of the servo-control manoeuvre joint.
- 2) insert the servo-control pushing it in the indicating direction.
- 3) insert the split pin in the hole.
- 4) make sure that the servo-control is correctly assembled.

The servo-control must be installed with the valves completely open.

The servo-controls are supplied in the "open" position and can be installed on all the series of ITAP zone valves.

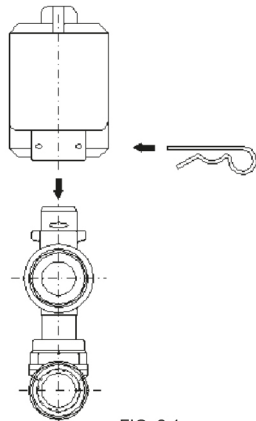

FIG. 2.1



FIG. 2.2

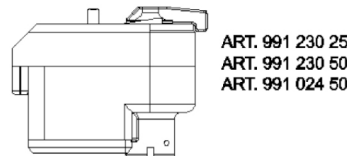
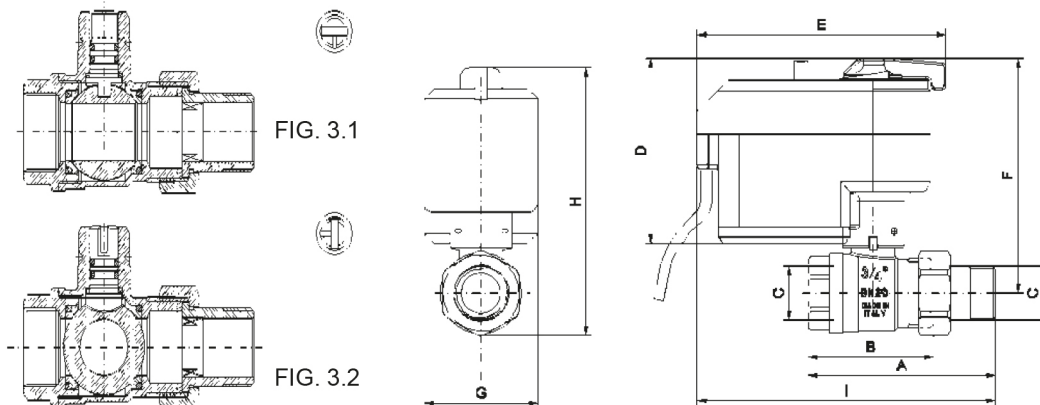

FIG. 2.3

2-Way Zone Valve:

The servo control operates on the valve with a 90° rotation passing from the open position to the closed position. Figure 3.1 shows the two-way valve in the "open" position. Figure 3.2 shows the valve in a "closed" position. The screwdriver cut corresponds to the open position of the valve. To avoid increases in differential pressure in the systems using 2-way zone valves, it is recommended to fit a bypass between the output and input or to use pumps with variable speeds.



	A	B	C	D	E	F	G	H	I	PRESSURE kg/cm ² - bar	LBS WORKING PRESSURE
3/4"	90.5	60.5	3/4"	92	120	114	55	134.5	144	16	230
1"	103	68.5	1"	92	120	118	55	143	152	16	230
1"1/4	116.5	78	1"1/4	92	120	123	55	152	160.5	16	230

WARNING:



ELECTRIC ACTUATORS AND ZONE BALL VALVES

The servo control must never be mounted facing downwards.

When installing in metal boxes it is necessary to leave enough space above the servo control for the unblocking device manoeuvres and for eventual maintenances or replacements.

To limit the overall dimensions, position the interception valves as illustrated in fig. 7.2,7.3

To install art 986 in boxes it is necessary to correctly line up the pipes with the coplanar manifold to avoid excessive stress between the servo motor and the valve unit.

FIG. 7.1

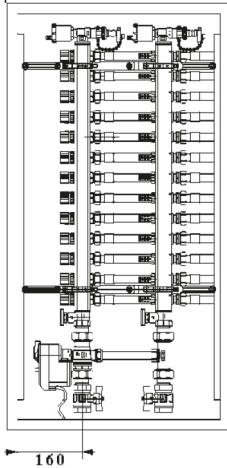

FIG. 7.2

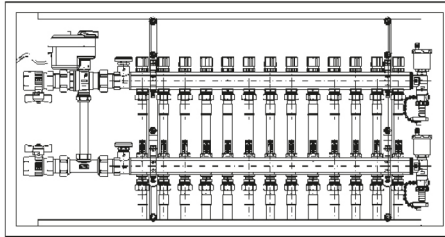
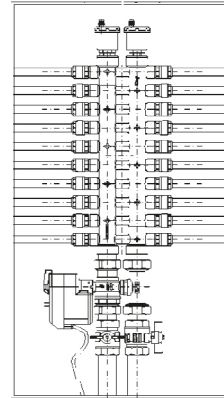

FIG. 7.3



Maximum tightening torques:

3/4" = 90 Nm

1" = 130 Nm

1"1/4 = 160 Nm